

# Raw GNSS Data Compression using Compressive Sensing for Reflectometry Applications

---

Bushra Ansari, Vishal Kaushik, Sanat K. Biswas  
Dept. of Electronics and Communication, IIT-Delhi



INDRAPRASTHA INSTITUTE *of*  
INFORMATION TECHNOLOGY  
DELHI



- Introduction
- Problem Statement
- Data set
- Simulation Setup for NavIC Data
- Mathematical Formulation
- Results and Discussion
- Conclusion



- **GNSS**

- An umbrella term for various global and regional navigation satellite systems.
- It includes GPS, Galileo, GLONASS, Beidou, NavIC etc.

- **GNSS-Reflectometry (GNSS-R)**

- Is a passive and in-expensive technique for remote sensing applications.
  - It is advantageous as it uses existing GNSS infrastructure.
- 

# Problem with Raw GNSS data

---



- The size of GNSS data is large which takes a long transmission time, while sending it wirelessly for GNSS Reflectometry analysis .
- The main aim is to develop an algorithm to reduce the amount of data to be stored onboard and downloaded to Earth, for reflectometry applications.
- This problem can be overcome by **compression** of GNSS data before transmission and then performing its **reconstruction** at the receiver end.

# Data Set

---

- The study presented in this paper is conducted on the real-time raw GPS and the NavIC data-set.
- The GPS IF data is from TDS-1 satellite which is available at FTP server <ftp://ftp.merrbys.co.uk>.
- The NavIC data for Reflected (i.e. multipath) scenario is simulated using the GNSS Simulator SIMAC2.



# Simulation setup for NavIC Data



- The NavIC data is simulated for two different surface properties (i.e. dielectric constant) using physics based model.
- After that, the bladeRF SDR is used to receive the NavIC data sets.
- These data sets are further processed for reflectometry application in MATLAB environment.

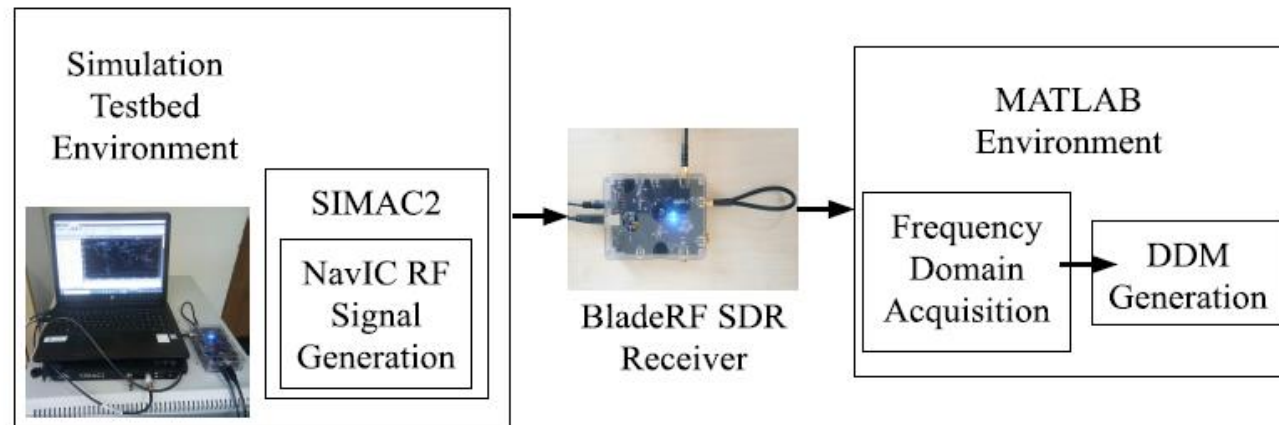

Fig 1. Simulation setup for NavIC signal Processing

# Mathematical Formulation



- For **Compression** the GNSS Signal is represented in sparse (DCT/DWT) Domain. Where  $D$  is DCT/DWT matrix of size  $M \times M$  and signal  $x$  of dimension  $M \times 1$ .

$$Dx = \Psi$$

- Construction of sparse signal  $y$  of size  $(N \times 1)$  by multiplying the signal with Toeplitz/Bernoulli/Gaussian matrix  $\Phi$  of size  $N \times M$ . Where  $N$  (i.e. No. of samples) depends on the sampling ratio.

$$y = \Phi x \text{ i.e. } y = \Phi D^{-1} \Psi$$

- Now, the signal **Reconstruction** is performed by solving the convex  $l_1$ -norm minimisation, using spgl toolbox.

$$\min \|Dx\|_1 \text{ s.t. } \|y - \Phi x\|_2^2 \leq \epsilon$$

$$\text{Where: } Dx = \Psi$$

$$\min \|\Psi\|_1 \text{ s.t. } \|y - \Phi D^{-1} \Psi\|_2^2 \leq \epsilon$$

- Finally, the signal  $x$  can be recovered as :

$$x = D^{-1} \Psi$$

# Signal Sparsity in DCT and DWT Domain



- The CS theory can be applied to GNSS signals as well, as it has a sparse representation in both Discrete Cosine Transform (DCT) and Discrete Wavelet Transform (DWT) domain.

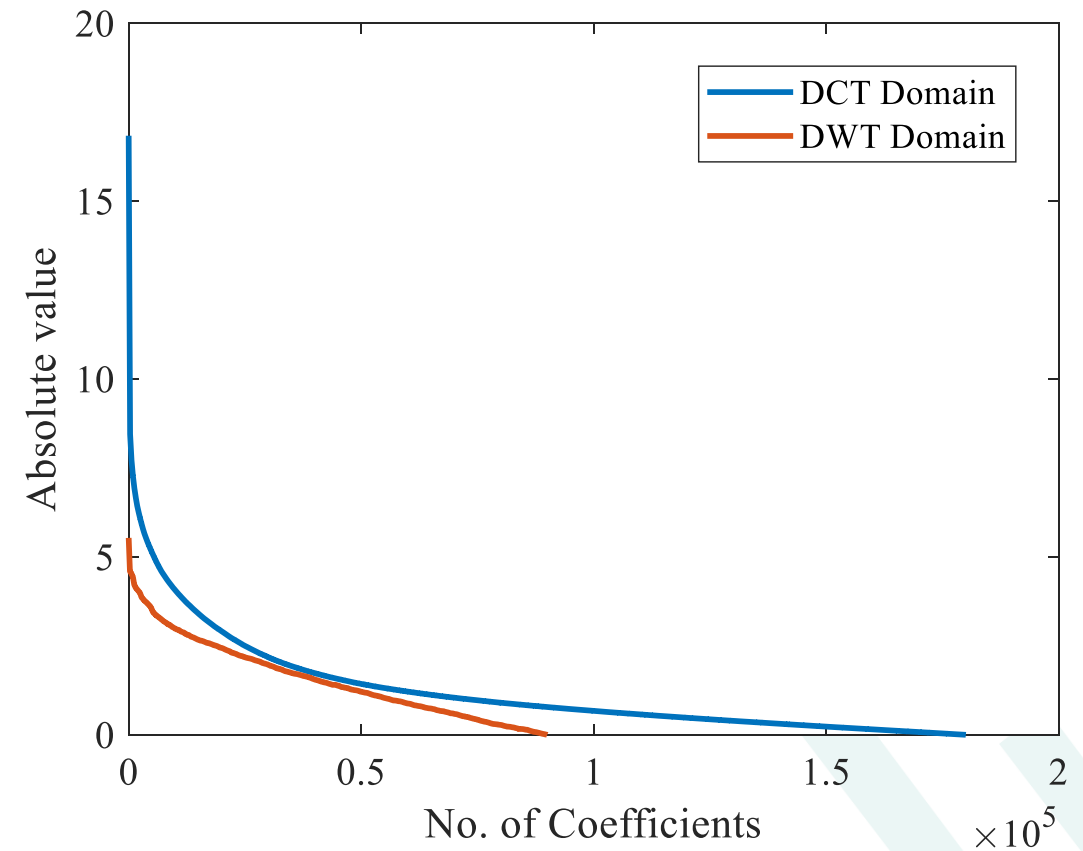

Fig 2. Sparse representation of GNSS signal in DCT and DWT domain.



# Results and Discussions



- The results are obtained for various sensing and sparsifying matrix as stated below:

Sensing Matrices Used - Gaussian, Bernoulli, Toeplitz

Sparsifying Matrix - DCT , DWT

Reconstruction algorithm - BPDN

- Further the frequency domain acquisition is performed on both the original and reconstructed data.
- For reflectometry application, the DDMs of two NavIC data sets for different surface properties (i.e. dielectric constant 5 and 20) are generated. The variation in correlation power levels of the DDM is then compared.

# DCT vs DWT Sparsifying matrix



- The performance of DCT and DWT sparsifying matrix is compared in terms of NMSE at different sampling ratio.

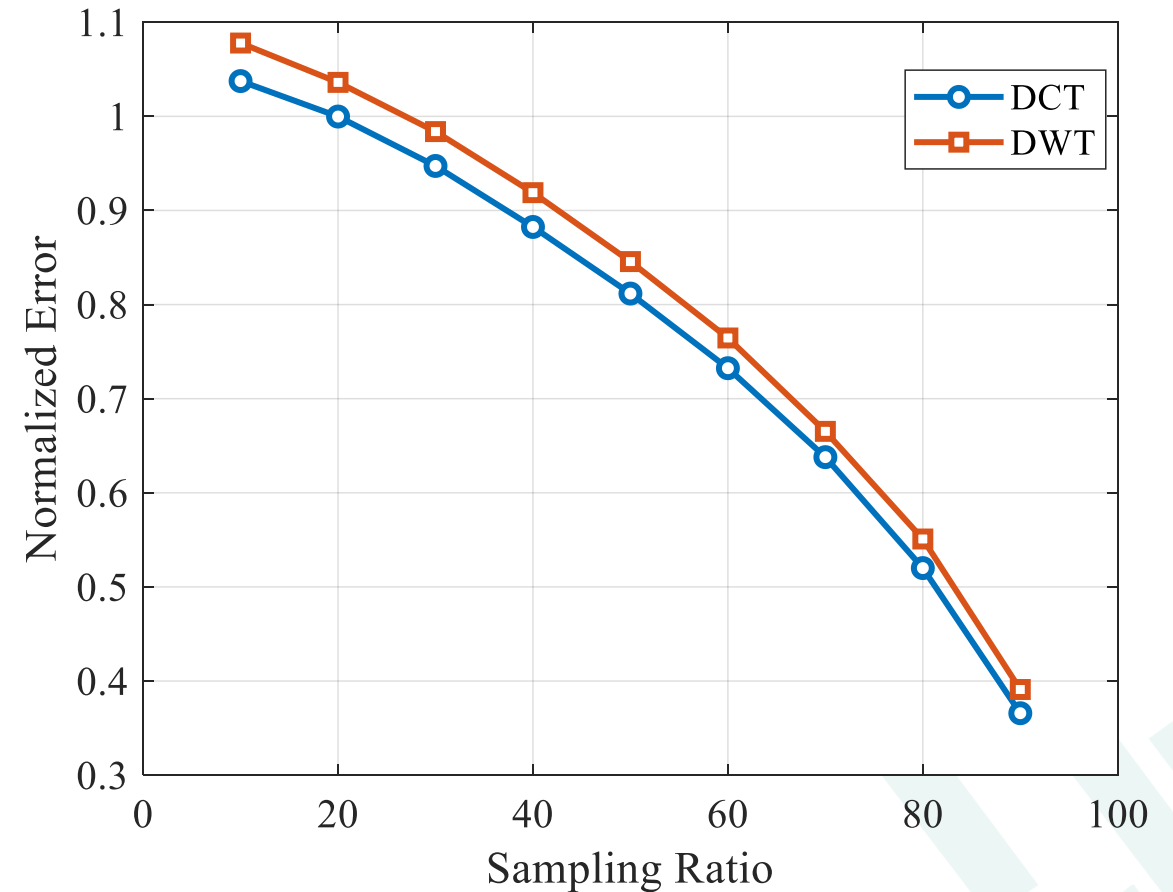

Fig 3. Comparison between DCT and DWT sensing matrix for different sampling ratio.

# DCT with Toeplitz / Bernoulli / Gaussian



- The performance of Toeplitz, Bernoulli and Gaussian measurement matrix is also evaluated.

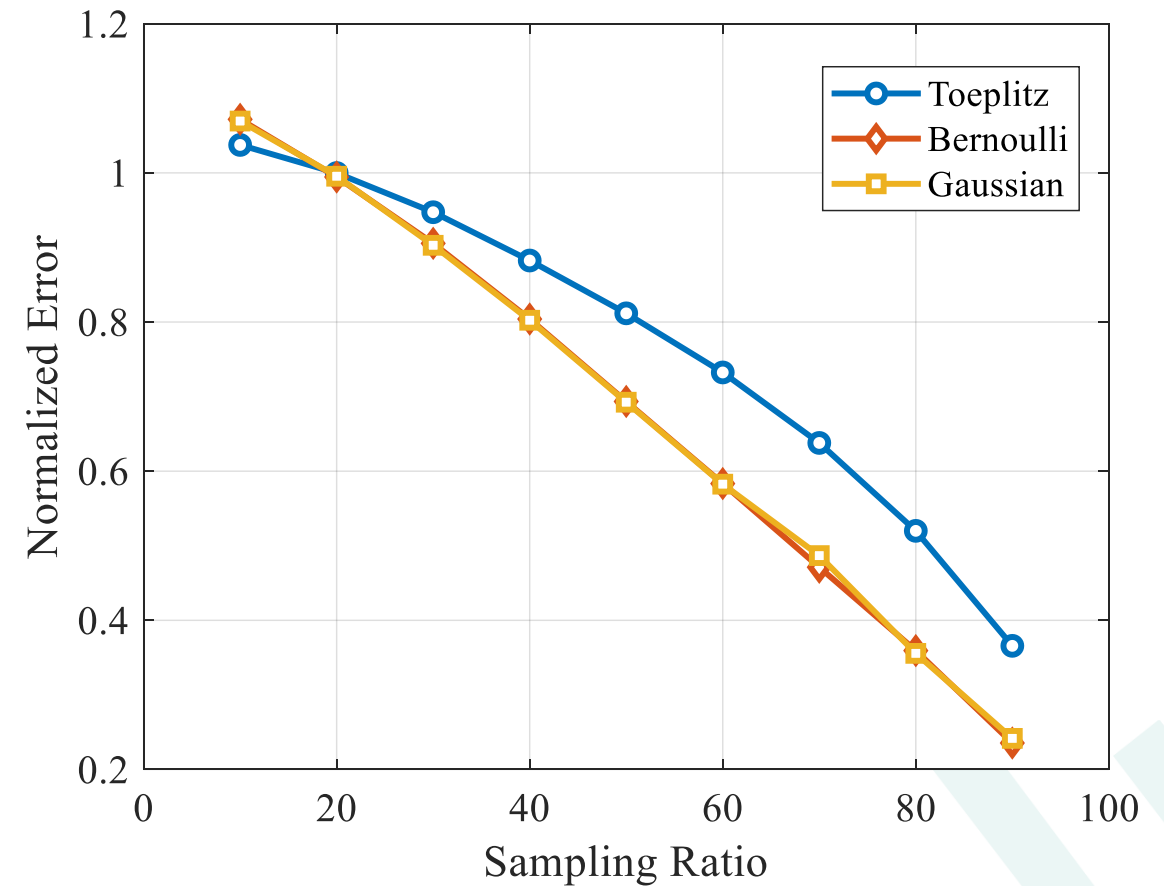

Fig 4. Comparison between Toeplitz, Bernoulli and Gaussian measurement matrix for different sampling ratio.

# Comparison of NavIC signal DDM



- For reflectometry application, the DDMs of two NavIC data sets for different surface properties (i.e. dielectric constant 5 and 20) are generated.
- The correlation power levels of the DDM shows variation depending on the surface properties.
- Moreover, the DDMs of the data which is reconstructed using the proposed algorithm also shows the variation in the correlation power.

Dielectric Constant	Correlation peak (Original Data set)	Correlation Peak (Reconstructed Data set)
5	2848	476.8
20	4176	849.9

Table 1. Change in correlation peak with different surface dielectric constant.

# DDM for the Multi-path NavIC signal

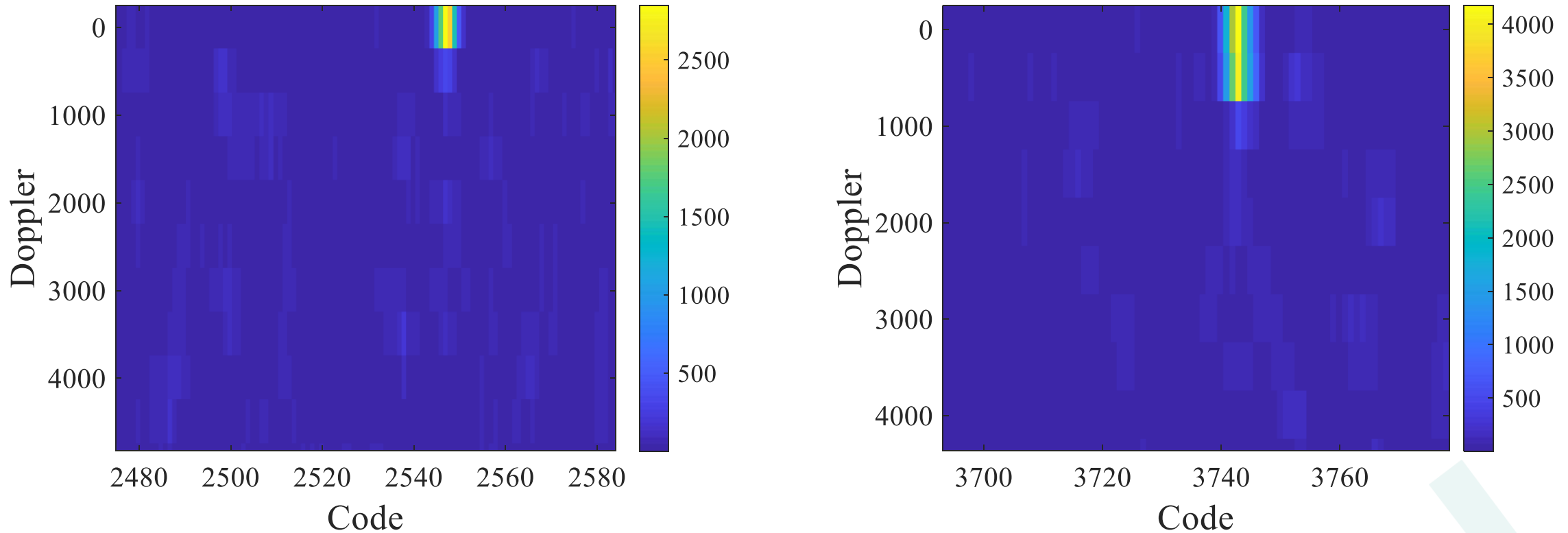

Fig 5. DDM Using Original Data for Dielectric constant 5 (a) and 20 (b)

# DDM for the Multi-path NavIC signal

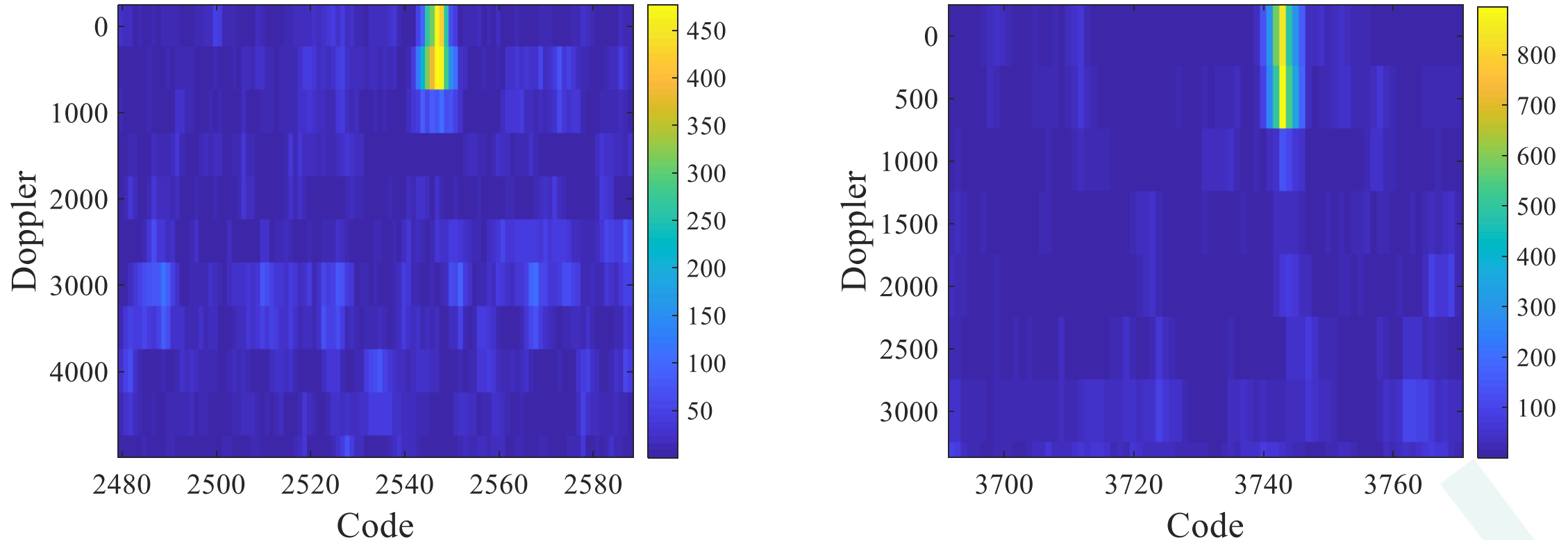

Fig 6. DDM Using Reconstructed Data for Dielectric constant 5 (a) and 20 (b)

# Conclusion

---



- Compressive Sensing based reconstruction algorithm is proposed that is reducing the data size for reflectometry application.
- The satellite acquisition is performed for both the original and reconstructed data sets and the same satellite PRN and code delay is detected for both data.
- It is feasible to differentiate between two surface properties (i.e. dielectric constant) from the DDMs generated from the reconstructed data.

---

Thank You

Email-Id : [bushraa@iiitd.ac.in](mailto:bushraa@iiitd.ac.in)

